

HFA/BML Mechanical block (for HFA300)

1) Before to insertion slot

After removing the existing screw from its original position and after closing the housing (with the other three M5X14 screws), a mechanical block (A) must be positioned where the screw was and must be fixed with an M5x20 screw (B), which comes together with the HFA/BML kit. After that, an insert (C) gets into the mechanical block and a padlock (D) which needs to be inserted in a dedicated slot (C), closes the device. In this way it will be no longer possible to remove the screw (and open the housing), as this is no more accessible.

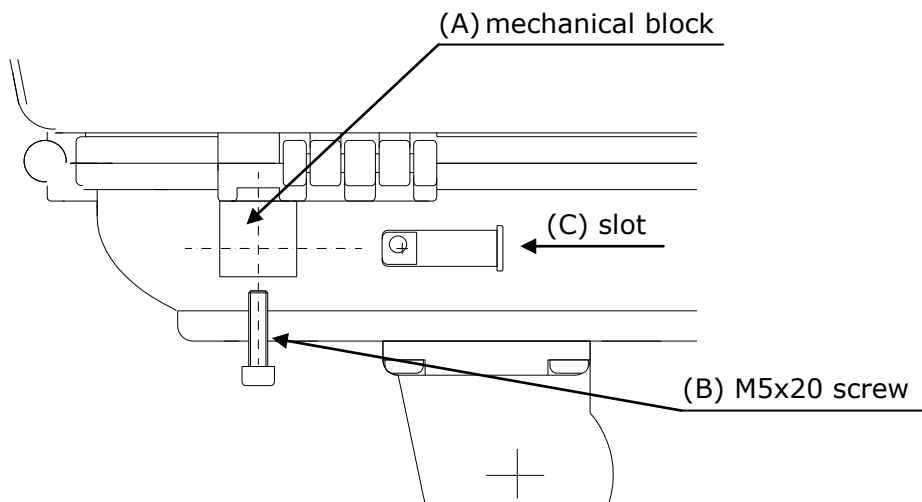

2) After to insertion slot

